

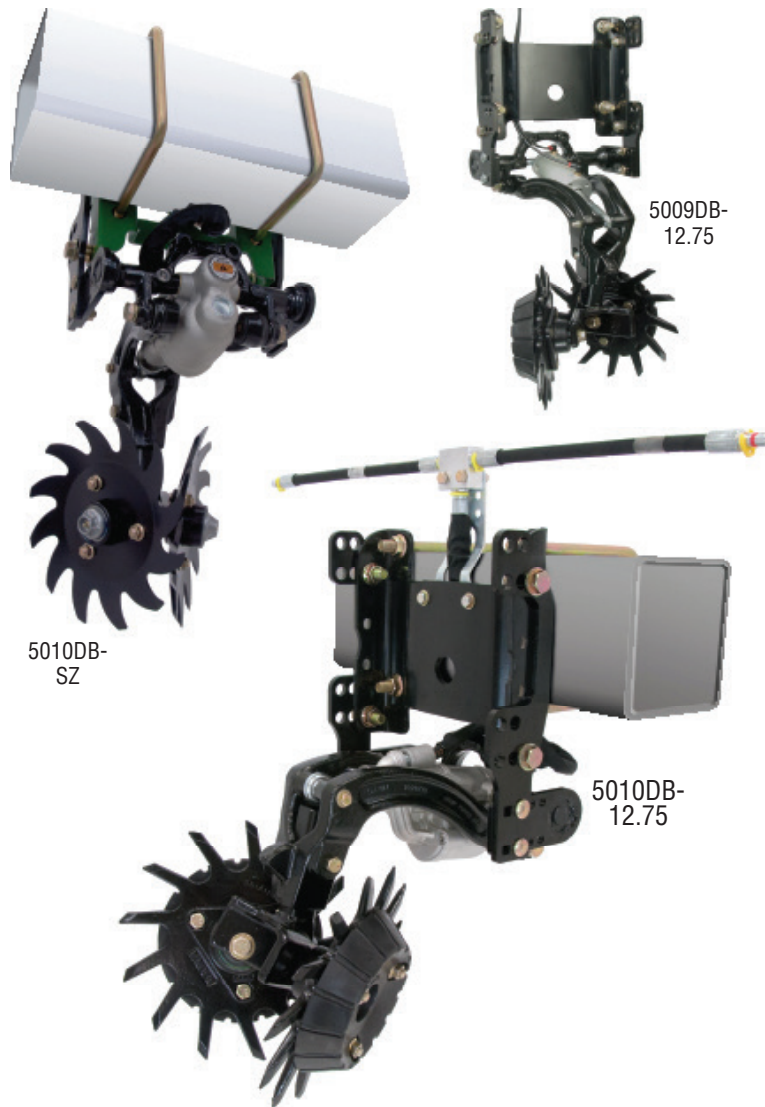

GFX FLOATING TRASHWHEEL®

REMOTE HYDRAULIC & PNEUMATIC ROW CLEANERS
MODELS 5010 / 5009 / 5008



5010DB-SZ

5009DB-12.75

5010DB-12.75

- Bulkhead connection plate keeps your hydraulic and pneumatic hoses tidy, and out of the way.
- Heavy-duty drop-forged support arms and row cleaners.
- Trashwheel® hubs run on **TIMKEN®** roller bearings.
- Fits most John Deere, Kinze, White and Case planters.
- Trashwheels® are guaranteed against bending or breaking.

The frame mounted, trailing-arm Gfx Row Cleaner follows ground contours, without gouging, even in very difficult field conditions. Mounting the row cleaner to the toolbar allows for independant control over the row cleaner and planter row unit. Planter attachments mounted to the planter row unit may affect spacing by jarring the seed meter, and emergence by causing irregularity in opener depth, as the unit encounters an infield obstacle.

In the hydraulic system, an integral hydraulic accumulator prevents the row cleaner from affecting the action of nearby units, and also absorbs pressure spikes from impact with infield obstacles.



Model #	Description
5010-12.75 5010-14	GFX HYDRAULIC TRASHWHEELS® Availbe with optional Depth Bands.
5009-12.75 5009-14	GFX PNEUMATIC TRASHWHEELS® Available with optional Depth Bands.
400124	FX ELECTRO-HYDRAULIC CONTROL KIT One kit per planter is required to control GFX units.
400219	FX ELECTRO-PNEUMATIC CONTROL KIT For use with any Dawn pneumatic system.

800.554.0007
dawnequipment.com



GFX - H

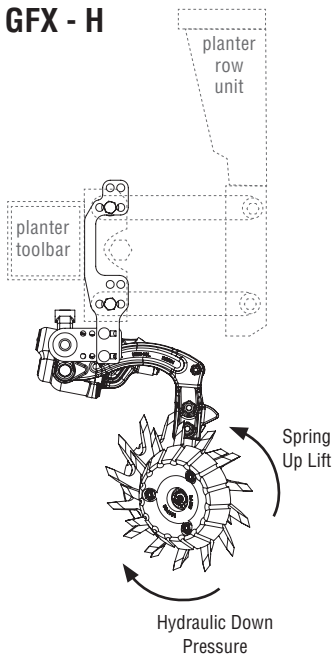

top view

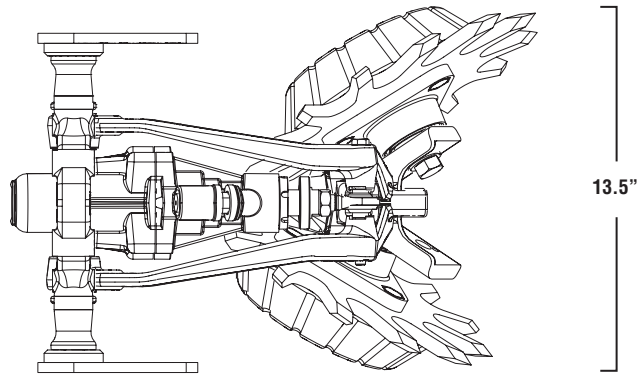

13.5"

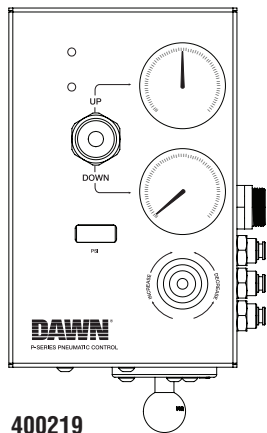

400219
Electro-Pneumatic
Control System

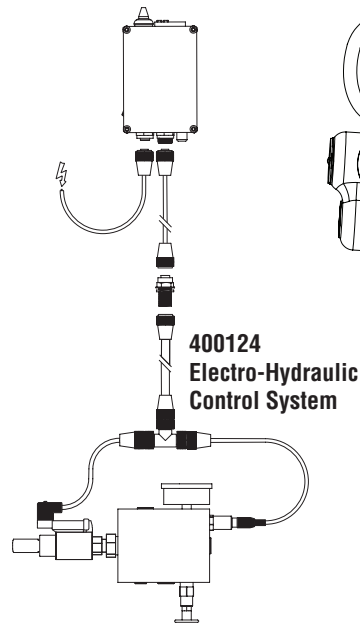

400124
Electro-Hydraulic
Control System

side view

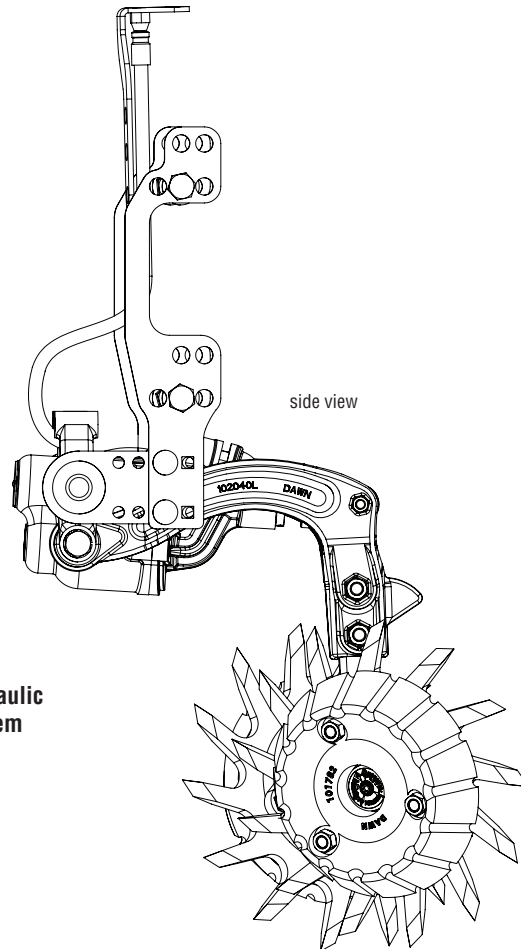

GFX - H Hydraulic Trashwheels®

Models 5010-12.75 / 5010DB-12.75

5010-14 / 5010DB-14 / 5010-SZ / 5010DB-SZ

Length 20 in.

Width 14.5 in.

Weight 80 lbs.

Down Pressure 0-120 lbs

Hyd. Pressure 800-2000 psi

Range of Travel ± 5 in.

GFX - P Pneumatic Trashwheels®

Models 5008 / 5009-12.75 / 5009DB-12.75

5009-14 / 5009DB-14 / 5009-SZ / 5009DB-SZ

Length 20 in.

Width 14.5 in.

Weight 65 lbs.

Down Pressure 0-120 lbs

Pneu. Pressure 0-120 psi

Range of Travel ± 5 in.

GFX Control Systems

Hydraulic 400124 / 400165GFX

Pneumatic 400219